

# Solar Kit for 15W 20W & 30W CCTV System



**15W : NexSolar-15W-v1 (100Ah Battery, 150W PV Module)**

**20W : NexSolar-20W-v1 (150Ah Battery, 200W PV Module)**

**30W : NexSolar-30W-v1 (200Ah Battery, 300W PV Module)**



Pole not included.

# CCTV Solar Kit selection guide

## Site location: Sydney, Brisbane, Perth

	NexSolar-15W-v1	NexSolar-20W-v1	NexSolar-30W-v1
Ideal for a camera with power consumption	<7W Typical	<12W Typical	<22W Typical
Example	QNO-C8013R QNO-8010R or similar	QNE-C9013RL XNO-A9084R or similar	PNM-C12083RVD QNP-6205R or similar
Battery	1280Wh 90% DoD 100Ah 12.8V	1920Wh 90% DoD 150Ah 12.8V	2560Wh 90% DoD 200Ah 12.8V
Solar Panel	150W	200W (2 × 100W)	300W (2 × 150W)
Autonomy (days, no sun):	3 days	3 days	3 days
Recovery days (sunny days to refill)	3.5 days	3.5 days	3.5 days

## Site location: Melbourne

	NexSolar-15W-v1	NexSolar-20W-v1	NexSolar-30W-v1
Ideal for a camera with power consumption	<4W	<7W	<12W
Example		QNO-C8013R QNO-8010R or similar	QNE-C9013RL XNO-A9084R or similar
Battery	1280Wh 90% DoD 100Ah 12.8V	1920Wh 90% DoD 150Ah 12.8V	2560Wh 90% DoD 200Ah 12.8V
Solar Panel	150W	200W (2 × 100W)	300W (2 × 150W)
Autonomy (days, no sun):	3 days	3 days	3 days
Recovery days (sunny days to refill)	3.5 days	3.5 days	3.5 days

## Other components

Type	Model
Controller	Raspberry Pi 4
Storage	1TB SSD
4G Router	RUT200

Type	Model
PoE Switch	TSW101
DC Converter	12/24 to 5 V DC converter
Data Converter	USB to RS485 converter

# Solar Panel

# 150 Watt 150M12

182mm 32Cells PV Module

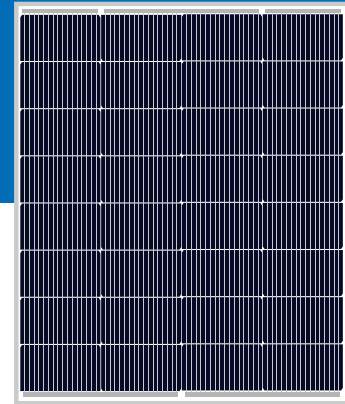

## Electrical Characteristics

Module Type	150M12
	STC
Maximum Power- Pmax(W)	150
Open Circuit Voltage - Voc(V)	22.30
Short- Circuit Current - Isc(A)	8.16
Voltage at Pmax - Vmp(V)	19.20
Current at Pmax - Imp(A)	7.81
Module Efficiency - $\eta$ m(%) Power	21.67
Tolerance(W)	0, +4.99W
Maximum System Voltage(V)	700Vdc (IEC / UL)
Maximum Series Fuse Rating (A)	15A

STC : Irradiance 1000W/m<sup>2</sup>, Cell Temperature 25 C , Air Mass 1.5

## Electrical Characteristics

External Dimensions	905*765*25mm
Weight	7.52kg
Solar Cells	Mono crystalline 182x105mm (4x8pcs)
Front Glass	2.0 mm tempered glass
Frame	Aluminum
Junction Box	IP67
Output Cables	90cm, length can be customized
Connector	MC4 Compatible
Mechanical Load	Front Side Max. 5400Pa, Rear Side Max. 2400Pa

## Temperature Characteristics

Pmax Temperature Coefficient	-0.290%/°C
Voc Temperature Coefficient	-0.250%/°C
Isc Temperature Coefficient	+0.045%/°C
Operating Temperature	-40~+85°C
Nominal Operating Cell Temperature(NOCT)	45±2°C

## Packing Configuration

Module Type	150M12
Module Dimensions	905*765*25mm
Pallet Dimensions	935x1115x110mm
Pallet Weight	355kg
Pieces/Pallet	43pcs

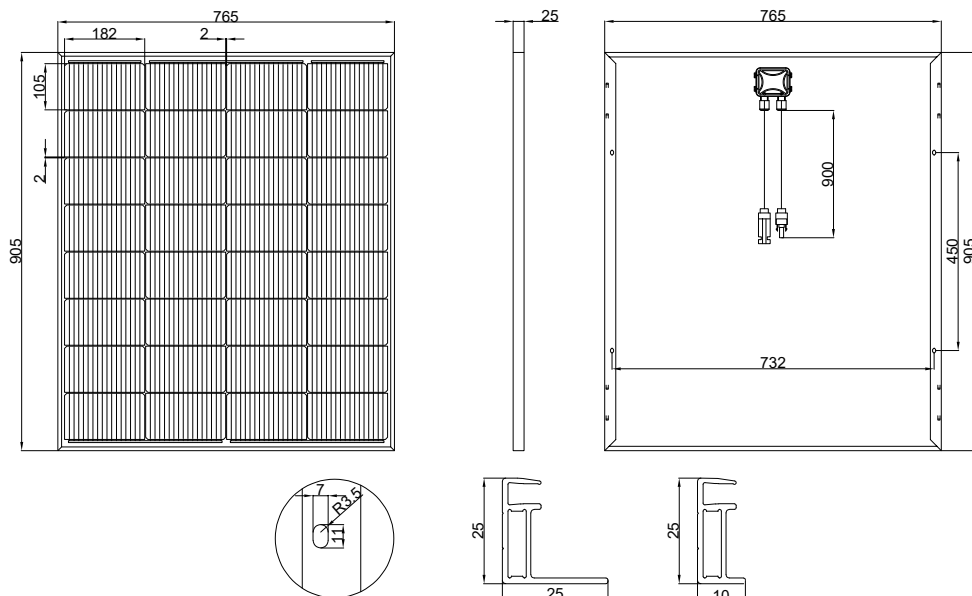
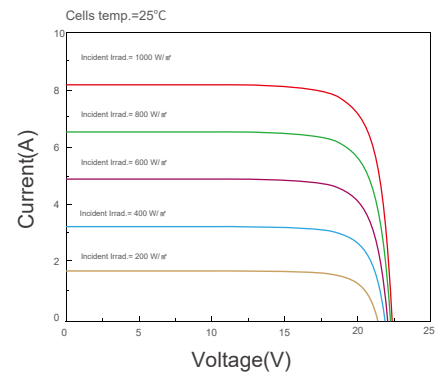

# Solar Panel

# 100 Watt 100M12

182mm 20Cells PV Module

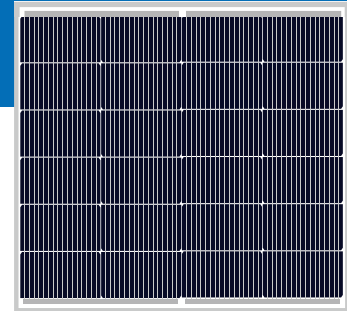

## Electrical Characteristics

Module Type	100
	STC
Maximum Power- Pmax(W)	100
Open Circuit Voltage - Voc(V)	21.00
Short- Circuit Current - Isc(A)	5.50
Voltage at Pmax - Vmp(V)	17.80
Current at Pmax - Imp(A)	5.62
Module Efficiency - $\eta$ m(%) Power	19.50
Tolerance(W)	0, +4.99W
Maximum System Voltage(V)	700Vdc (IEC / UL)
Maximum Series Fuse Rating (A)	15A

STC : Irradiance 1000W/m<sup>2</sup>, Cell Temperature 25 C , Air Mass 1.5

## Electrical Characteristics

External Dimensions	630*765*30mm
Weight	5.5kg
Solar Cells	Mono crystalline 182x105mm (4x5pcs)
Front Glass	2.0 mm tempered glass
Frame	Aluminum
Junction Box	IP67
Output Cables	90cm, length can be customized
Connector	MC4 Compatible
Mechanical Load	Front Side Max. 5400Pa, Rear Side Max. 2400Pa

## Temperature Characteristics

Pmax Temperature Coefficient	-0.290%/°C
Voc Temperature Coefficient	-0.250%/°C
Isc Temperature Coefficient	+0.045%/°C
Operating Temperature	-40~+85°C
Nominal Operating Cell Temperature(NOCT)	45±2°C

## Packing Configuration

Module Type	100M12
Module Dimensions	630*765*30mm
Pallet Dimensions	935x1115x110mm
Pallet Weight	355kg
Pieces/Pallet	43pcs

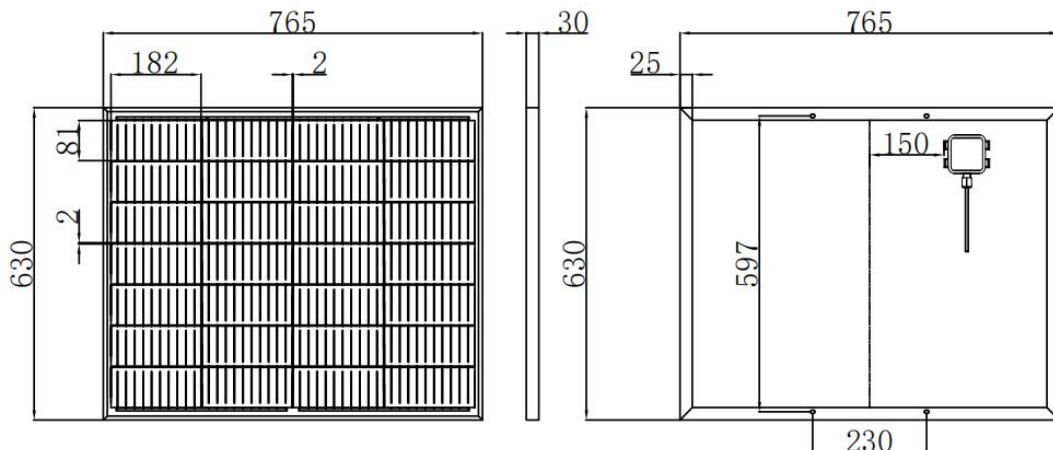
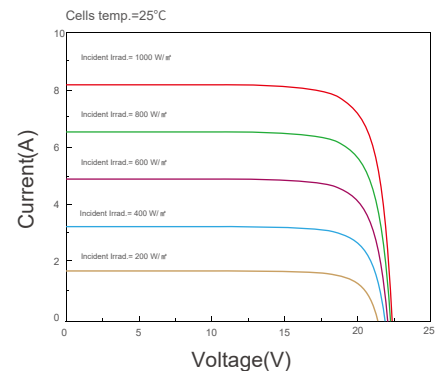

# LFP Battery

## 1. Scope

This product specification applies for Li-ion battery pack that supplied by EOS Australia Pty Ltd.

## 2. Overview

- This battery integrates a solar MPPT charging system
- This battery integrates a DC24-DC12 module
- This battery supports under voltage protection and automatic power recovery function, which can achieve unmanned operation.
- This battery can support RS485 communication
- This battery is suitable for outdoor environments and can be installed on poles.

## 3. Battery & Com Cabinet

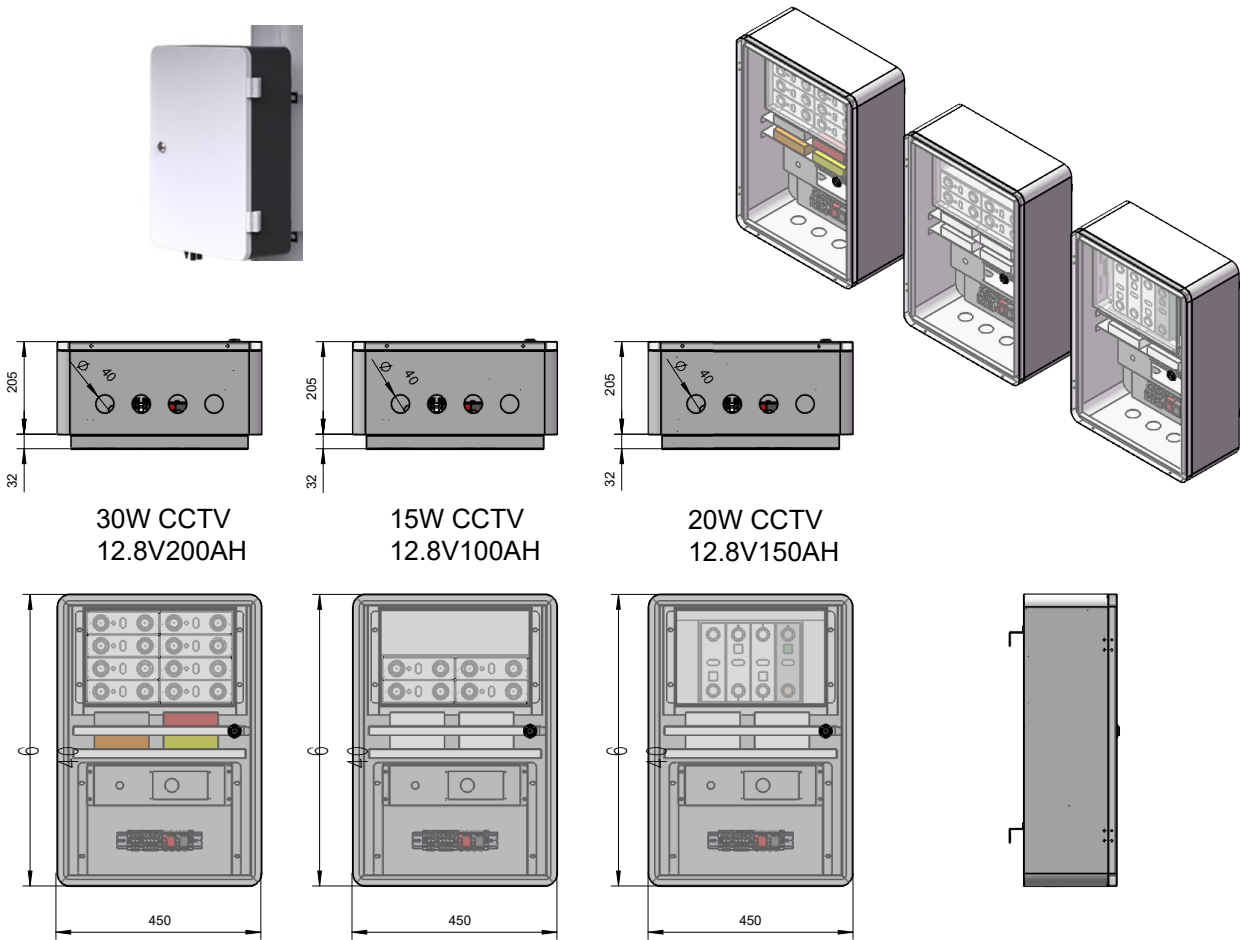

## 4. Dimension Drawing

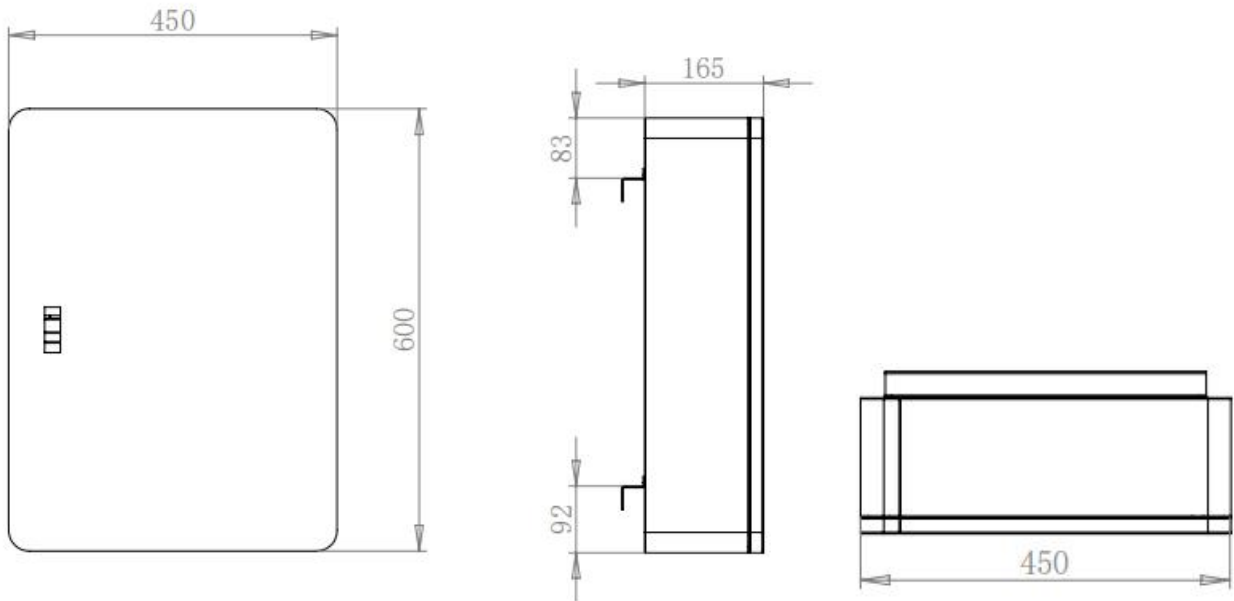

## 5. Installation Approach

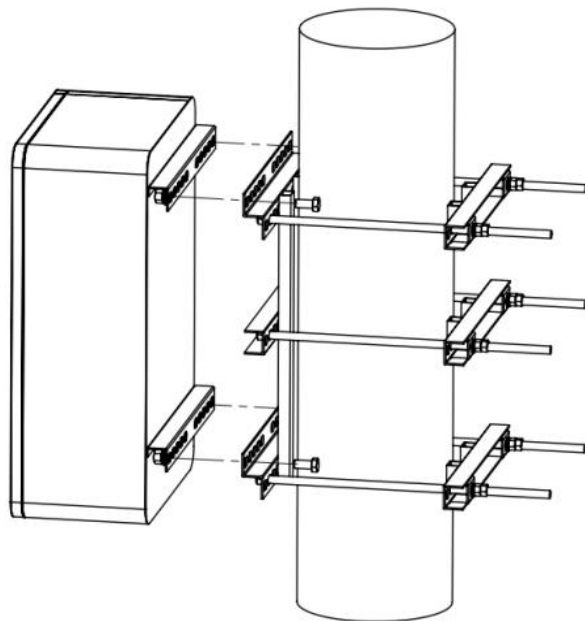



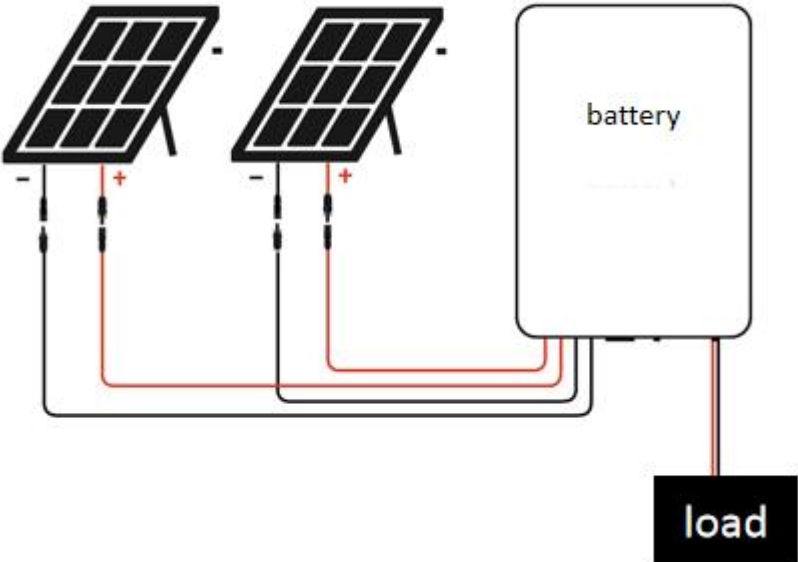

# 6.Nominal Specification

Charge	Maximum PV Open Circuit Voltage	100Vdc
	Maximum Photovoltaic Charging Power	300W
	Solar Charging Current Range	0-20A
	Solar controller model	Tracer 2210AN G3
	Charging type	MPPT
Energy Storage Performance	Battery Type	LiFeP04
	Battery Capacity	1280wh(100Ah) 1920wh(150Ah) 2560wh(200Ah)
	Nominal Voltage	12.8V
	Voltage Range	10Vdc-14.6Vdc
	Cycle Number	4000 cycles capacity 80%
Output Performance	Dc Output Voltage	10Vdc-14.6Vdc
	Dc Output Power	480W
	DC OUTPUT CURRENT(MAX)	20A
	Dc Output Efficiency	95%
Protection Type	overcharge protection, undervoltage protection, short circuit protection, reverse protection, temperature protection, etc	
Other Properties	Operating Temperature Range	0-65°C
	Humidity Division	5%to95%
	Communication	RS485
	Dimension	600*450*165mm
	Waterproof	IP55
	weight	35Kg (200AH)



## 7.product list

NO.	Item	Quantity	Unit	PIC
1	Energy storage cabinet	1	Set	
2	Cabinet bracket	1	pcs	
3	Column fixture	2	pcs	
4	Bracket bolt group M10 * 200	4	set	
5	Photovoltaic cable 4m*2	1	set	
6	corrugated tube	4	m	
7	Bellows connector	2	pcs	

## 8 Cell characteristics

### 8.1 Testing Conditions (unless otherwise specified)

Temperature:  $25 \pm 2^\circ\text{C}$

Relative Humidity: 45%~75%

Atmospheric pressure: 86~106Kpa Standard

Charge:

Under  $25 \pm 2^\circ\text{C}$ , it can be charged to 14.8V with constant current of 0.5C, and then, charged continuously with constant voltage of 14.4V until the charged current is 0.05C.

Standard discharge method :

Under  $25 \pm 2^\circ\text{C}$ , it can be discharged to 8 V with 0.5C current.

### 8.2 Electrical Characteristics

NO	ITEM	Testing Instruction	Requirements
1	Rated Capacity	After standard charge, rest for 30 minutes, then discharge in standard discharge mode, rest for 30 minutes, cycle three times.	200Ah model $\geq 2560\text{wh}$ At least one capacity $\geq 2560\text{wh}$
2	High and low temperature Discharge performance	After standard battery charging, the battery is placed in the discharge environment for 19.25h at $-20^\circ\text{C}$ and 5h at $60^\circ\text{C}$ , respectively. Then the battery is discharged at 0.5C constant current at the discharge ambient temperature.	Discharge capacity/Original capacity: $-20^\circ\text{C} \geq 50\%$ $60^\circ\text{C} \geq 95\%$

3	Cycle Life	After standard charge, rest for 10 minutes, then standard discharge, rest for 10 minutes, cycle charge and discharge until the discharge capacity is lower than 80% of the initial capacity	Cycle NO. $\geq 4000$
4	Storage Characteristics	After standard charging, battery was stored at $25\pm 2^{\circ}\text{C}$ for 28 days, and then discharged in standard discharge mode	residual capacity/Original discharge capacity $\geq 94\%$
		After standard charging, battery was stored at $55\pm 2^{\circ}\text{C}$ for 7 days, and then discharged in standard discharge mode	$\geq 90\%$ residual capacity/Original discharge capacity $\geq 90\%$

### 8.3 Environmental & Mechanical Characteristic

NO	(ITEM)	(Testing Instruction)	(Requirements)
1	temperature cycling testing	After standard charging, the battery pack is stored at $72\pm 2$ ° C for 6 hours and then at $40\pm 2$ ° C for 6 hours. The temperature conversion time should be less than 30 minutes.Repeat the temperature cycle 10 times, and then store at ambient temperature for 24 hours.	No leakage, no exhaust,no disintegration, no rupture and no fire, the voltage is greater than 90% of the initial voltage
2	High altitude-low pressure	The battery pack is charged according to the standard charging system;The battery is put into the low-pressure chamber, the pressure in the test chamber is adjusted to 11.6KPa, the temperature is room temperature, and the battery stands for 6h;Stop the test, remove the battery and observe for 1h.	
3	Seawater immersion	After standard charging of the battery pack, the single battery is immersed in 3.5% NaCl solution (mass fraction, simulating the composition of seawater at normal temperature) for 2h;The water should be completely up to the battery pack.	No explosion, no fire

## 9. Warranty period & Product liability

Warranty period of this product is 24 months from purchase.

EOS is not responsible for the troubles caused by mishandling of the battery which is clearly against the instructions in this specification.

When EOS find any new facts which require modification of this document, we will inform you again.

## 10. Indications on battery pack

The following warnings should be indicated on the battery packs.

Use a specified charger.

Do not throw the battery into fire, or heat.

Do not short-circuit the battery terminals

Do not disassemble the battery.

## 11. Warnings and cautions in handling the Lithium-ion battery

To prevent a possibility of the battery from leaking, heating or explosion please observe the following precautions:

Do not use or leave the battery at very high temperature (for example, at strong direct sunlight or in a vehicle in extremely hot weather). Otherwise, it can overheat or fire or its performance will be degenerated and its service life will be decreased.

Do not use it in a location where static electricity is great, otherwise, the safety devices may be damaged, causing hidden trouble of safety.

If the battery leaks, and the electrolyte get into the eyes. Do not rub eyes, instead, rinse the eyes with clean running water, and immediately seek medical attention. Otherwise, it may injure eyes or cause a loss of sight.

If the battery gives off an odor, generates heat, becomes discolored or deformed, or in any way appear abnormal during use, recharging or storage, immediately remove it from the device or battery charger and stop using it.

In case the battery terminals are dirty, clean the terminals with a dry cloth before use. Otherwise power failure or charge failure may occur due to the poor connection with the instrument.

Be aware discarded batteries may cause fire, tape the battery terminals to insulate them

---